

MULTI-POINT CLOSURES FOR SLIDING SYSTEMS



Multi-point closures for sliding systems

Stainless and galvanized steel versions

Backset of 7.5 mm and 15 mm

Wide range of heights

Versions with pre-assembled anti-lifting device and security against false operation

Closures in galvanized steel tested in salt spray and classified in digit 4 (480 hours)

New multipoint closures: security slides quickly and easily



More points, more security

Multi-point locking systems boost security of doors and windows and throughout the home.



Versatility is its strength

New system physically and aesthetically suitable to each profile. Latter with cylinder available in stainless or galvanised steel.



Smart lock

Stainless and galvanized steel versions are factory-fitted with mishandling device, which prevents unintentional damage if you turn the cockspur handle when the sliding door/window is open.

Versatility is child's play.

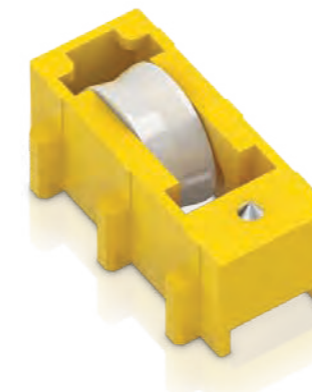
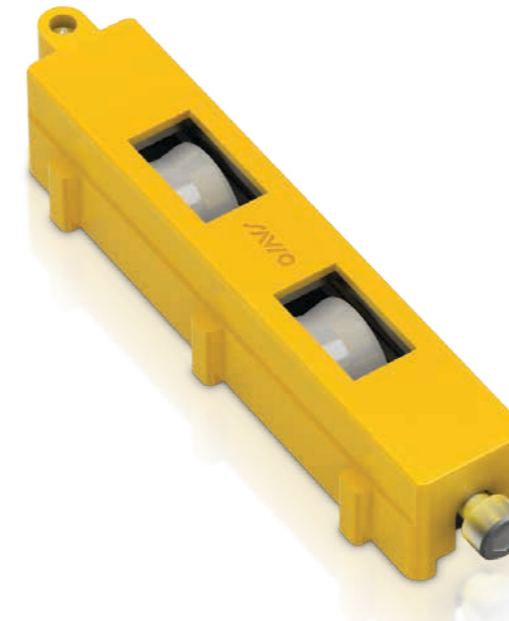

The new rollers for sliding doors and windows are suitable for both non-thermal and thermal break profiles.

Smooth enough for effortless opening of every sliding door or window.

Strong enough for weight capacity of up to 200 Kg for 25,000 cycles.

Technical features:

- Adjustment in millimetre increments with stainless steel locking screw.
- Fixing on profile with pre-assembled grub screws.
- Tested for 25,000 cycles in compliance with EN 13126-15: 2008.
- Weight capacity of up to 220 kg per leaf.
- Suitable for both non-thermal and thermal break profiles.

Application scheme on sliding window



Application scheme on sliding window

- ① 2154.7/30
2154.7/30X
2154.7/60
2154.7/60X
2154.7/100
2154.7/100X
2154.7/180
2154.7/180X
- ② 2154.801/..
2154.802/..
2154.803/..
2154.804/..
2154.811/..
- ③ 866.3/7
866.4/7
874.3/7
874.4/7
1610/7
- ④ 2154.15/30
2154.15/30X
2154.15/60
2154.15/60X
2154.15/100
2154.15/100X
2154.15/180
2154.15/180X
2154.751/180
- ⑤ 2061
- ⑥ 2203.1/2
2203.51/120
2203.51/180
2203.52/120
2203.52/180
- ⑦ 2150.1
2151.1
2152.1
2156.1
A29624300

Double rollers

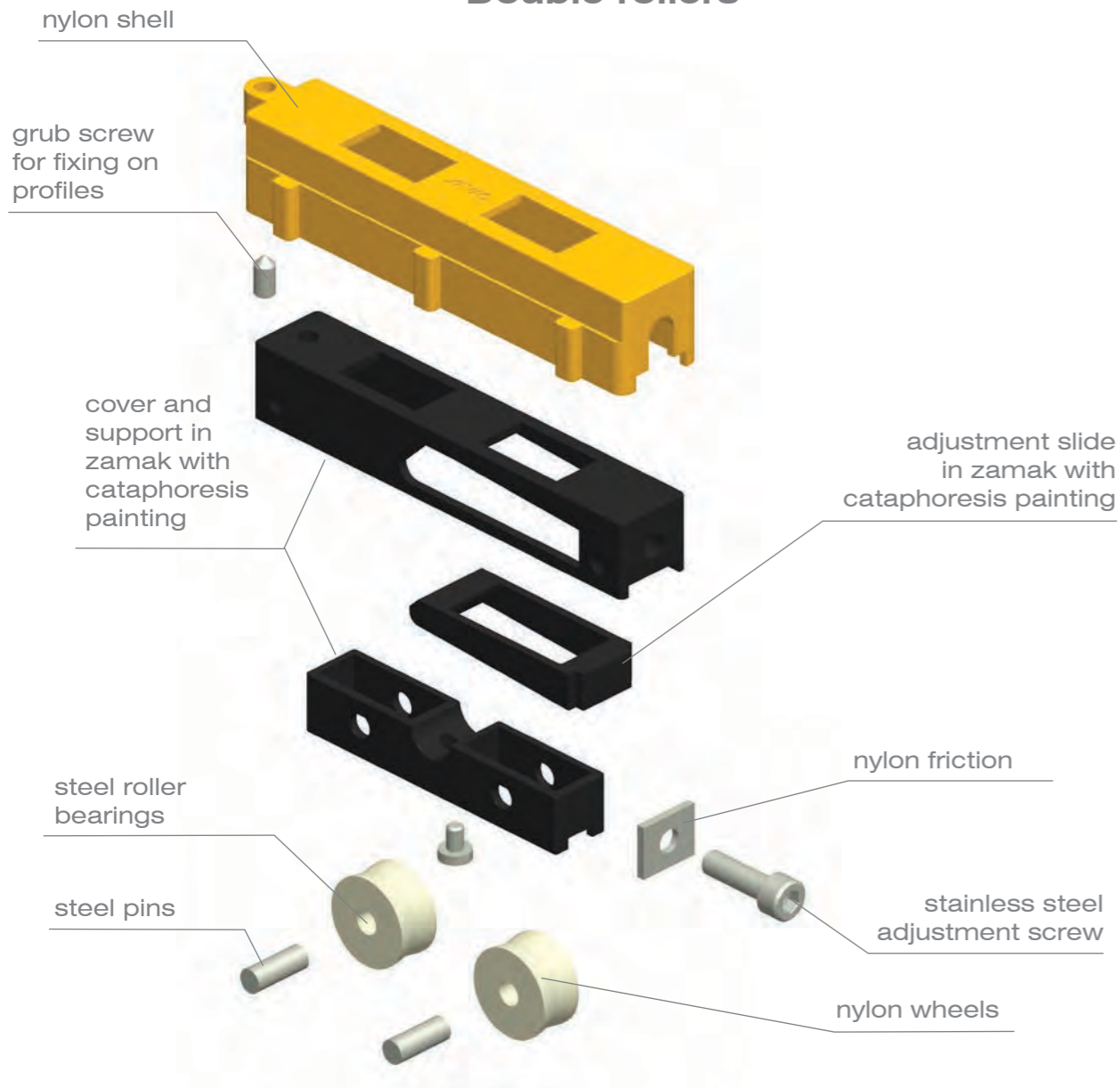

Single rollers

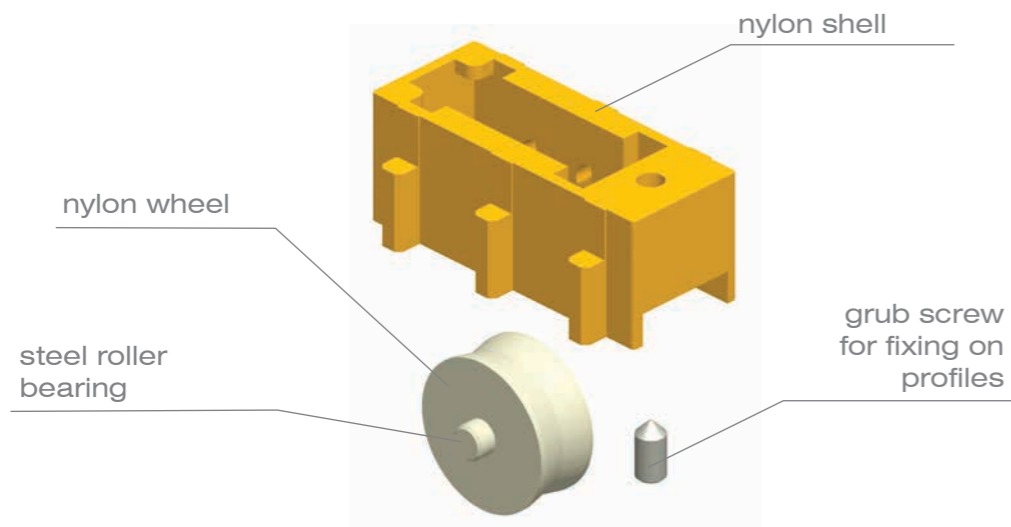

Multi-point closures

Item	Description	Pcs.	Finishes
2154.7/30	Multi-point closure for sliding systems in galvanized steel, 1 closing point, with anti-lifting device, backset of 7.5 mm. Length of 300 mm. Tested 480 hours in salt spray.	6	





Item	Description	Pcs.	Finishes
2154.7/30X	Multi-point closure for sliding systems in stainless steel, 2 closing points, backset of 7.5 mm. Length of 300 mm.	6	

Item	Description	Pcs.	Finishes
2154.7/60	Multi-point closure for sliding systems in galvanized steel, 2 closing points, with anti-lifting device and security against false operation, backset of 7.5 mm. Length of 600 mm. Tested 480 hours in salt spray.	6	





Item	Description	Pcs.	Finishes
2154.7/60X	Multi-point closure for sliding systems in stainless steel, 2 closing points, with anti-lifting device and security against false operation, backset of 7.5 mm. Length of 600 mm.	6	

Item	Description	Pcs.	Finishes
2154.7/100	Multi-point closure for sliding systems in galvanized steel, 2 closing points, with anti-lifting device and security against false operation, backset of 7.5 mm. Length of 1000 mm. Tested 480 hours in salt spray.	6	

Multi-point closures

Item	Description	Pcs.	Finishes
 2154.7/100X	Multi-point closure for sliding systems in stainless steel, 2 closing points, with anti-lifting device and security against false operation, backset of 7.5 mm. Length of 1000 mm.	6	
 2154.7/180	Multi-point closure for sliding systems in galvanized steel, 3 closing points, with anti-lifting device and security against false operation, backset of 7.5 mm. Length of 1800 mm. Tested 480 hours in salt spray.	6	
 2154.7/180X	Multi-point closure for sliding systems in stainless steel, 4 closing points, with anti-lifting device and security against false operation, backset of 7.5 mm. Length of 1800 mm.	6	
 2154.15/30	Multi-point closure for sliding systems in galvanized steel, 1 closing point, with anti-lifting device, backset of 15 mm. Length of 300 mm. Tested 480 hours in salt spray.	6	
 2154.15/30X	Multi-point closure for sliding systems in stainless steel, 2 closing points, backset of 15 mm. Length of 300 mm.	6	

Multi-point closures

Item	Description	Pcs.	Finishes
 2154.15/60	Multi-point closure for sliding systems in galvanized steel, 2 closing points, with anti-lifting device and security against false operation, backset of 15 mm. Length of 600 mm. Tested 480 hours in salt spray.	6	
 2154.15/60X	Multi-point closure for sliding systems in stainless steel, 2 closing points, with anti-lifting device and security against false operation, backset of 15 mm. Length of 600 mm.	6	
 2154.15/100	Multi-point closure for sliding systems in galvanized steel, 2 closing points, with anti-lifting device and security against false operation, backset of 15 mm. Length of 1000 mm. Tested 480 hours in salt spray.	6	
 2154.15/100X	Multi-point closure for sliding systems in stainless steel, 2 closing points, with anti-lifting device and security against false operation, backset of 15 mm. Length of 1000 mm.	6	
 2154.15/180	Multi-point closure for sliding systems in galvanized steel, 3 closing points, with anti-lifting device and security against false operation, backset of 15 mm. Length of 1800 mm. Tested 480 hours in salt spray.	6	

Multi-point closures

Item	Description	Pcs.	Finishes
2154.15/180X	Multi-point closure for sliding systems in stainless steel, 4 closing points, with anti-lifting device and security against false operation, backset of 15 mm. Length of 1800 mm.	6	
2154.751/180	Multi-point closure for sliding systems preset for cylinder, 3 closing points, in galvanized steel, with anti-lifting device and security against false operation, backset of 15 mm. Length of 1800 mm. Tested 480 hours in salt spray.	6	

Handles

Item	Description	Pcs.	Finishes
874.3/7	MANON (patented) Handle with handle in die-cast metal, base and cap in zamak, distance between centres of 43 mm, 7 mm square spindle with a projecting part of 24.5 mm and 2 cap screws M5x35 in galvanized steel.	5	1013, 1015, 1035, 7032, 7035, 8019, 9001, 9005, 9010, B.MA, B.SA, BL10, BR5, BR801, C, GR217, GR51, GR606, GREY, PVD H, PVD X, SILV
874.4/7	MANON (patented) Handle with handle in die-cast metal, base and cap in zamak, distance between centres of 43 mm, 7 mm square spindle with projecting part of 52 mm and 2 cap screws M5x60 in galvanized steel.	5	1013, 1015, 8019, 9001, 9005, 9010, 9016, B.MA, B.SA, BL10, BR5, BR801, C, GR217, GREY, PVD H, PVD X, SILV
866.3/7	ARIANNA Handle with handle in zamak, distance between centres of 43 mm, 7 mm square spindle with a projecting part of 24.5 mm and 2 cap screws M5x35 in galvanized steel.	5	1013, 8019, 9005, 9010, B.MA, BL10, BR5, C, GR217, PVD H, PVD X, SILV
866.4/7	ARIANNA Handle with handle in zamak, distance between centres of 43 mm, 7 mm square spindle with a projecting part of 52 mm and 2 cap screws M5x60 in galvanized steel.		1013, 8019, 9005, 9010, B.SA, BL10, BR5, C, GR217, PVD H, PVD X, SILV
1610/7	Handle with grip in aluminium, 7 mm square spindle with a projecting part of 38 mm and 2 countersunk head screws M5x45 in galvanized steel.	25	9005, 9016, F, U
2061	Recessed handle with grip and base in zamak, distance between centres of 43 mm, square spindle of 7 mm, 2 countersunk head screws M5x50 in stainless steel and 1 nylon cover machining cap.	20	9005, 9010, SILV

Multi-point closure fitting kit

Item	Description	Pcs.	Finishes
2154.801/30	Fitting kit for multi-point closures of 300 mm, including: 2 nylon lock shims, 1 nylon spacer, 2 nylon keeper shims, 1 zamak adapter for anti-lifting device, 2 keepers in stainless steel 304, 6 self-drilling countersunk head screws Ø 3.5x19 mm in stainless steel. For NC 60 Int. profiles.	12	
2154.802/30	Like 2154.801/30 but for Win 90 S profiles.	12	
2154.803/30	Like 2154.801/30 but for Domal Slide PA 80 profiles.	12	
2154.804/30	Like 2154.801/30 but for Triall.co 65 S/65 TT profiles.	12	
2154.811/30	Like 2154.801/30 but for Skeit 60/Export 60 S profiles.	12	
2154.801/60	Fitting kit for multi-point closures of 600 mm, including: 6 nylon lock shims, 1 nylon spacer, 3 nylon keeper shims, 1 zamak adapter for anti-lifting device, 1 nylon shim for security against false operation, 2 keepers in stainless steel 304, 12 self-drilling countersunk head screws Ø 3.5x19 mm in stainless steel. For NC 60 Int. profiles.	12	
2154.802/60	Like 2154.801/60 but for Win 90 S profiles.	6	
2154.803/60	Like 2154.801/60 but for Domal Slide PA 80 profiles.	12	
2154.804/60	Like 2154.801/60 but for Triall.co 65 S/65 TT profiles.	12	
2154.811/60	Like 2154.801/60 but for Skeit 60/Export 60 S profiles.	12	
2154.801/100	Fitting kit for multi-point closures of 1000 mm, including: 7 nylon lock shims, 1 nylon spacer, 3 nylon keeper shims, 1 zamak adapter for anti-lifting device, 1 nylon shim for security against false operation, 2 keepers in stainless steel 304, 13 self-drilling countersunk head screws Ø 3.5x19 mm in stainless steel. For NC 60 Int. profiles.	12	
2154.802/100	Like 2154.801/100 but for Win 90 S profiles.	6	
2154.803/100	Like 2154.801/100 but for Domal Slide PA 80 profiles.	12	
2154.804/100	Like 2154.801/100 but for Triall.co 65 S/65 TT profiles.	12	
2154.811/100	Like 2154.801/100 but for Skeit 60/Export 60 S profiles.	12	
2154.801/180	Fitting kit for multi-point closures of 1800 mm, including: 11 nylon lock shims, 1 nylon spacer, 5 nylon keeper shims, 1 zamak adapter for anti-lifting device, 1 nylon shim for security against false operation, 4 keepers in stainless steel 304, 19 self-drilling countersunk head screws Ø 3.5x19 mm in stainless steel. For NC 60 Int. profiles.	2	
2154.802/180	Like 2154.801/180 but for Win 90 S profiles.	6	
2154.803/180	Like 2154.801/180 but for Domal Slide PA 80 profiles.	6	
2154.804/180	Like 2154.801/180 but for Triall.co 65 S/65 TT profiles.	6	
2154.811/180	Like 2154.801/180 but for Skeit 60/Export 60 S profiles.	12	





Rollers and kit for sliding systems

Item	Description	Pcs.	Finishes
2150.1	Adjustable double roller in zamak varnished in cathaphoresis and nylon, steel roller bearings, stainless steel screws. Weight capacity: max 180 Kg/leaf. For Export 60 S, NC 60 Int. and Skeit 60 profiles.	40	
2151.1	Like 2150.1 but with polymer roller bearings and weight capacity max 120 Kg/leaf.	40	

Rollers and kit for sliding systems

Item	Description	Pcs.	Finishes
	2150.4 Adjustable double roller in zamak varnished in cataphoresis and nylon, steel roller bearings, stainless steel screws. Weight capacity: max 220 Kg/leaf. For Triall.co 65/TT and 90/TT profiles.	40	
	2151.4 Like 2150.4 but with polymer roller bearings and weight capacity max 120 Kg/leaf.	40	
	2152.1 Adjustable double roller in galvanized steel and nylon, steel ball bearings, stainless steel screws. Weight capacity: max 90 Kg/leaf. For Export 60 S, NC 60 Int. and Skeit 60 profiles.	40	
	2156.1 Adjustable roller in nylon, steel ball bearings, stainless steel screws. Weight capacity: max 50 Kg/leaf. For Export 60 S, NC 60 Int. and Skeit 60.	40	
	2156.4 Adjustable roller in nylon, steel ball bearings, stainless steel screws. Weight capacity: max 50 Kg/leaf. For Triall.co 65/TT and 90/TT profiles.	40	
	2157.4 Nylon roller adjustable in 2 positions, steel roller bearings, stainless steel screws. Weight capacity: max 100 Kg/leaf. For Triall.co 65/TT and 90/TT profiles.	40	

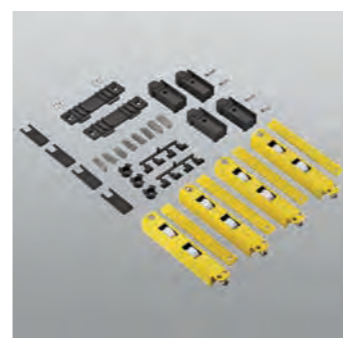
Rollers and kit for sliding systems

Item	Description	Pcs.	Finishes
	A29624300 Adjustable double roller in zamak varnished in cataphoresis and nylon, steel roller bearings, stainless steel screws. Weight capacity: max 220 Kg/leaf. For Win 90 S and Win 90 S TT.	40	
	2203.1 Kit of 2 nylon anti-dust caps, 4 self-adhesive sealing blocks, 4 cover machining caps, 4 nylon sash-blocking devices, 8 nylon alignment corner cleats, 3 nylon water-drain bushings, 4 self-tapping cap screws Ø4.2x9.5 in stainless steel. For NC 60 Int. profiles.	10	
	2203.2 Kit of 2 nylon anti-dust caps, 4 self-adhesive sealing blocks, 4 cover machining caps, 4 nylon sash-blocking devices, 8 nylon alignment corner cleats, 3 nylon water-drain bushings, 4 self-tapping cap screws Ø4.2x9.5 in stainless steel. For Export 60 S profiles.	10	
	2203.51/120 Sliding kit including: 4 rollers art. 2151.1 (weight capacity max 120 Kg) and 1 sliding kit art. 2203.1. For NC 60 Int. profiles.	10	
	2203.51/180 Sliding kit including: 4 rollers art. 2150.1 (weight capacity max 180 Kg) and 1 sliding kit art. 2203.1. For NC 60 Int. profiles.	10	
	2203.52/120 Sliding kit including: 4 rollers art. 2151.1 (weight capacity max 180 Kg) and 1 sliding kit art. 2203.2. For Export 60 S profiles.	10	
	2203.52/180 Sliding kit including: 4 rollers art. 2150.1 (weight capacity max 180 Kg) and 1 sliding kit art. 2203.2. For Export 60 S profiles.	10	

Multi-point closures

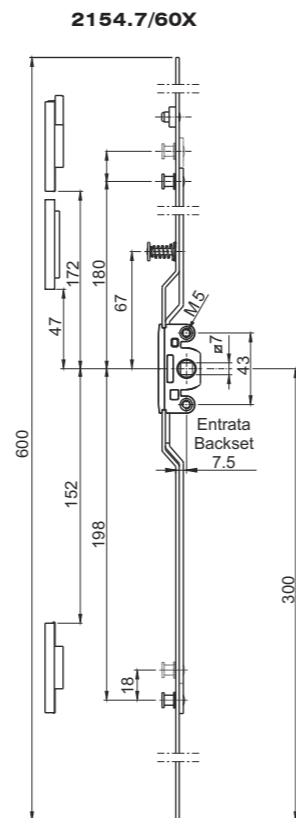
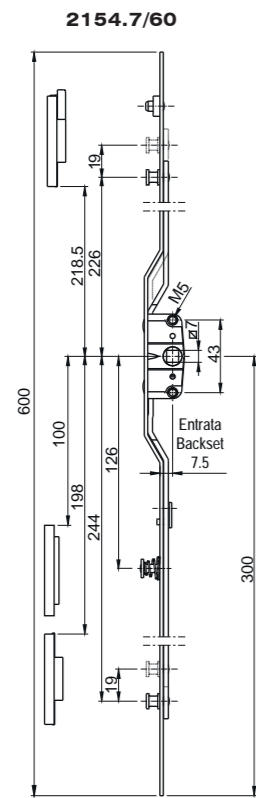
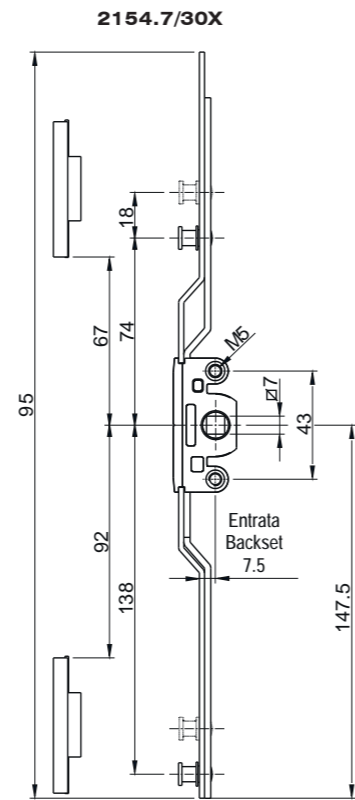
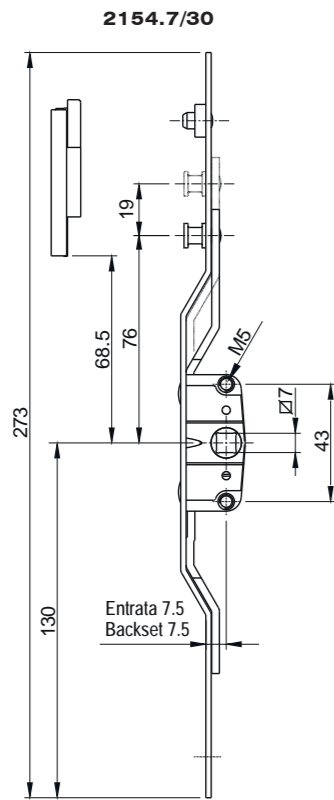

Multi-point closures

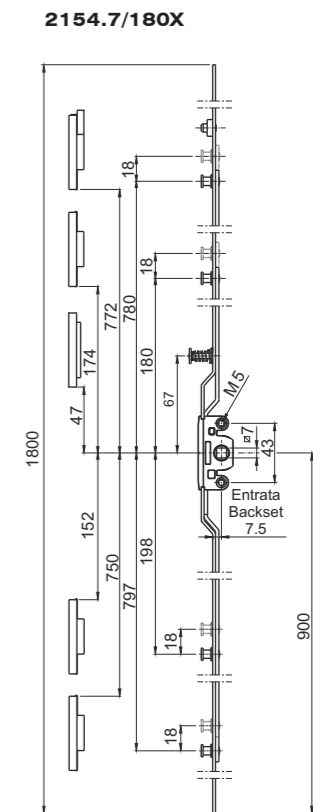
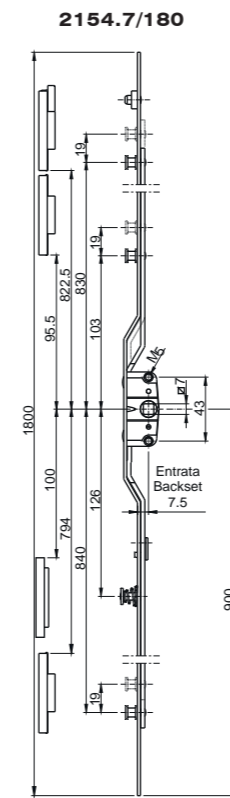
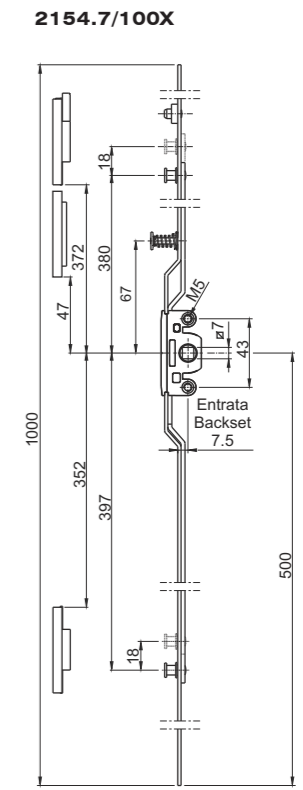
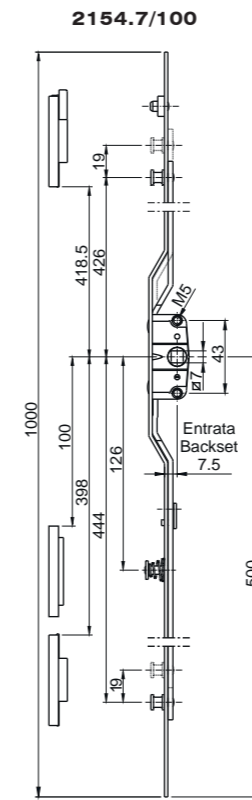

Multi-point closures

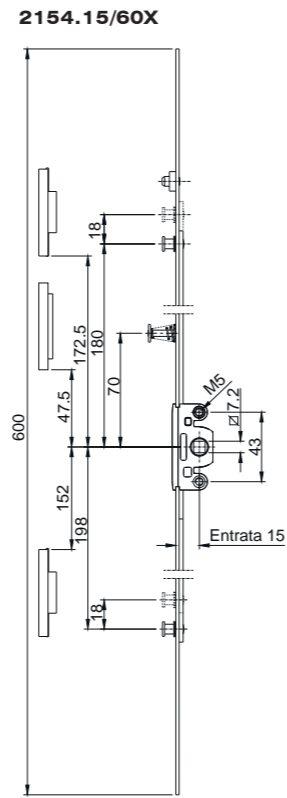
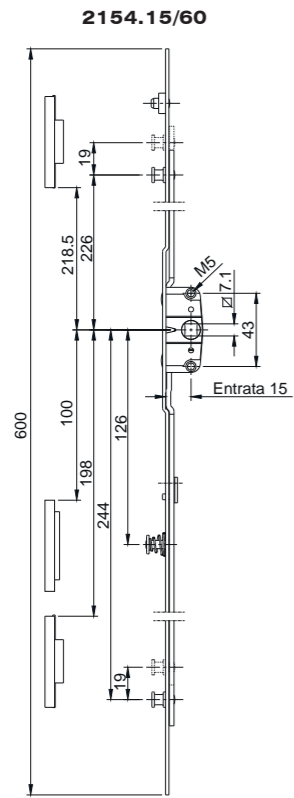
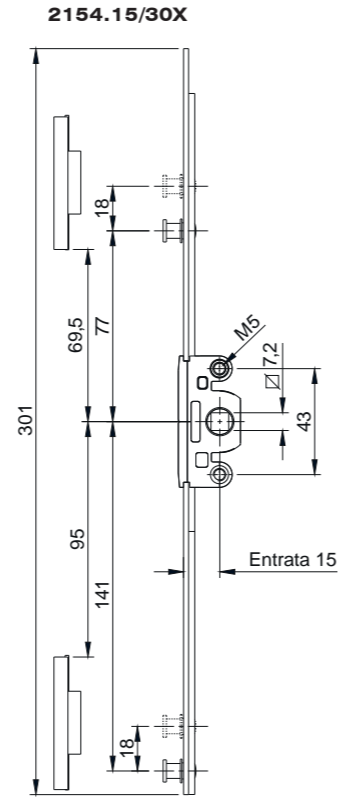
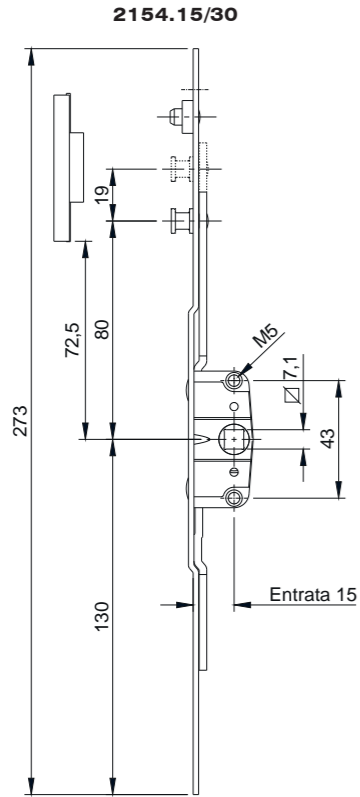

Multi-point closures

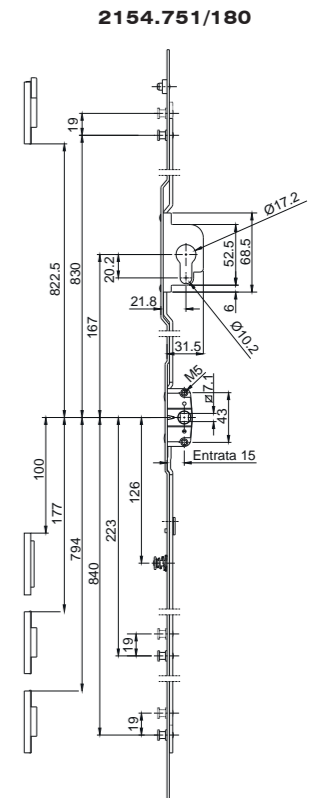
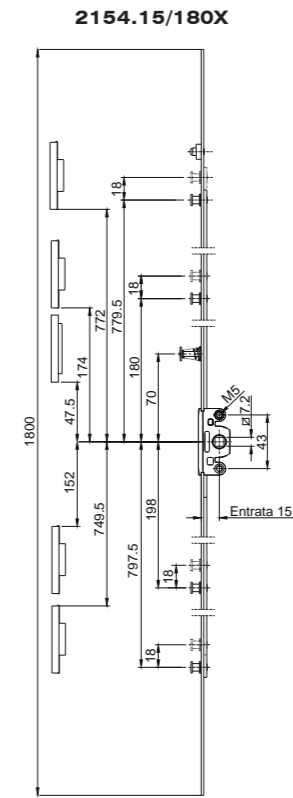
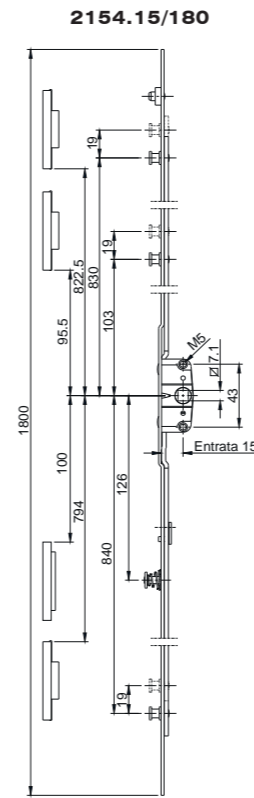
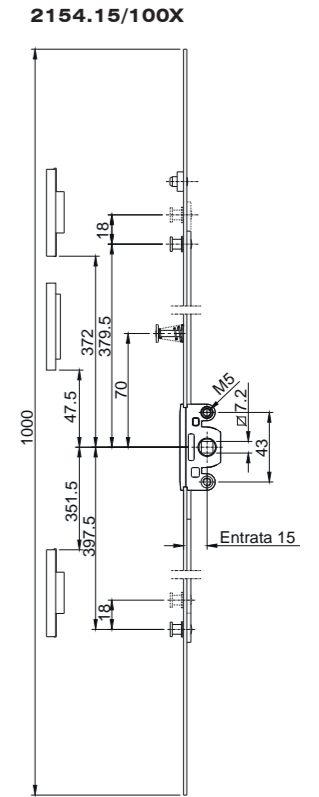
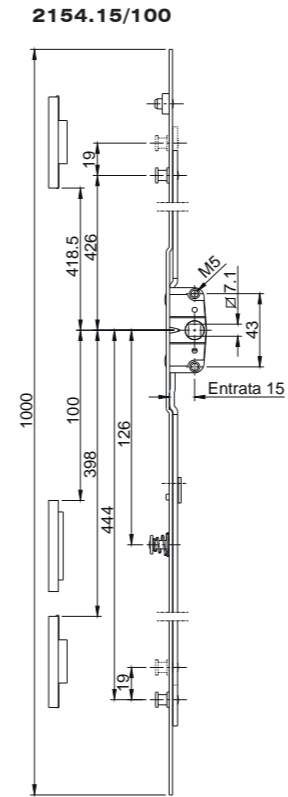

Handles

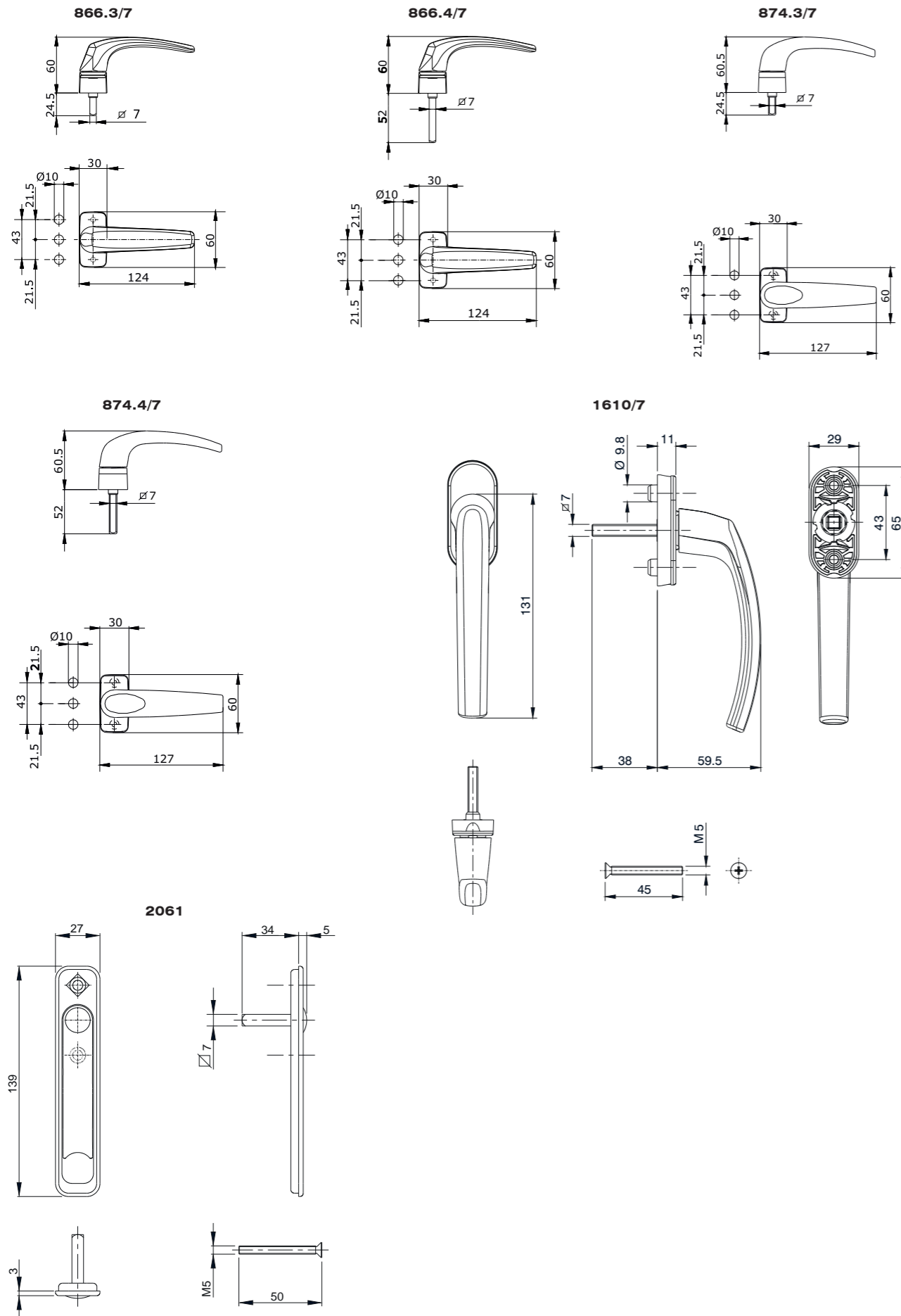

Fitting kit

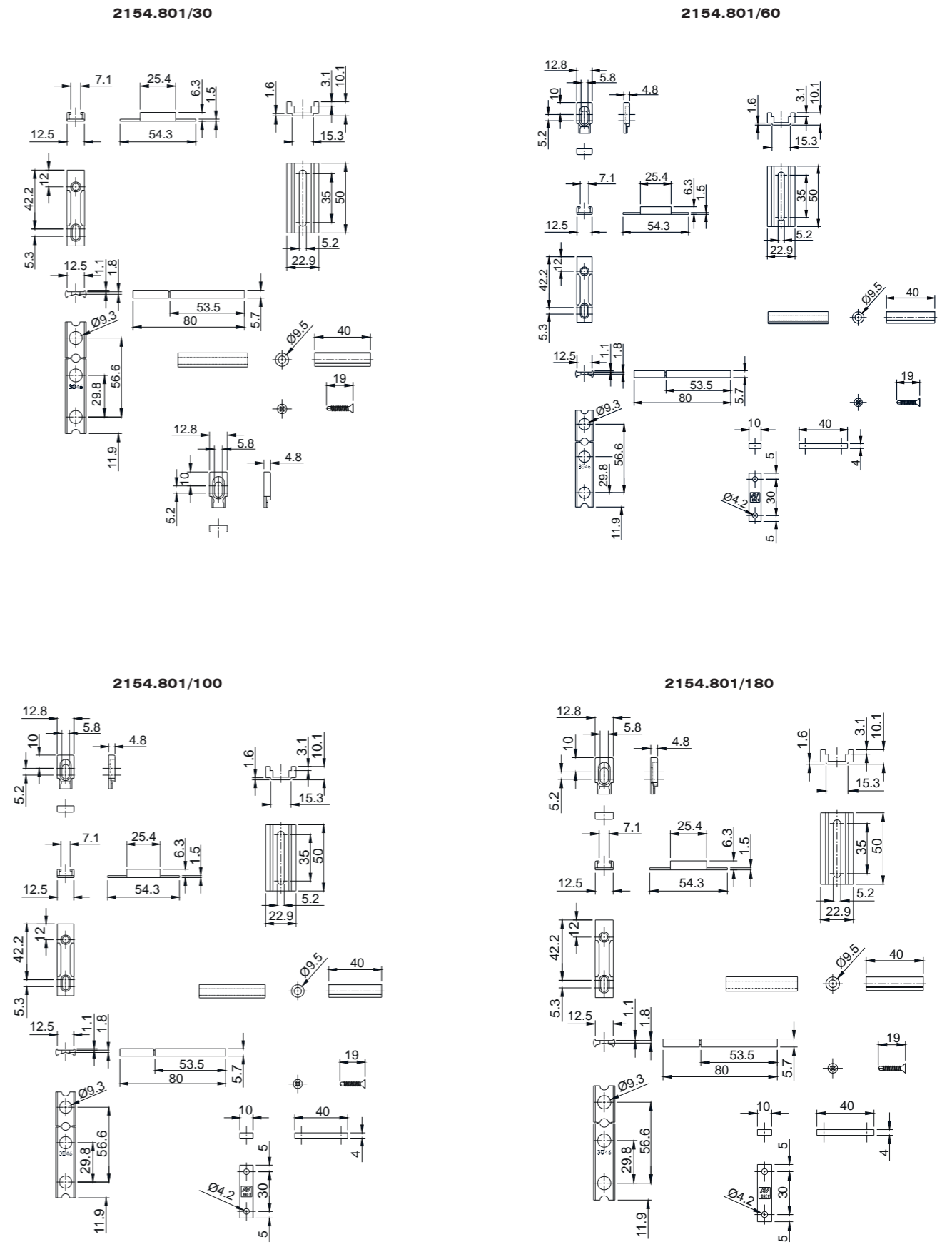

Rollers and kit for sliding systems

2150.1 - 2151.1

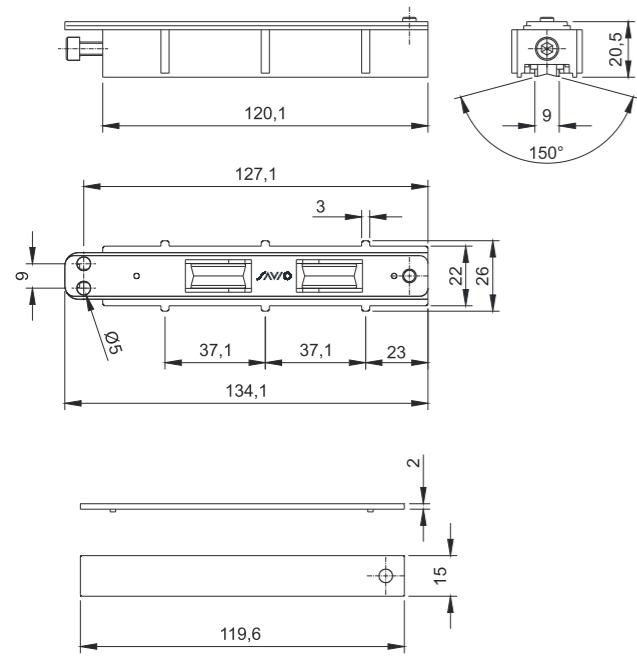

2150.4 - 2151.4

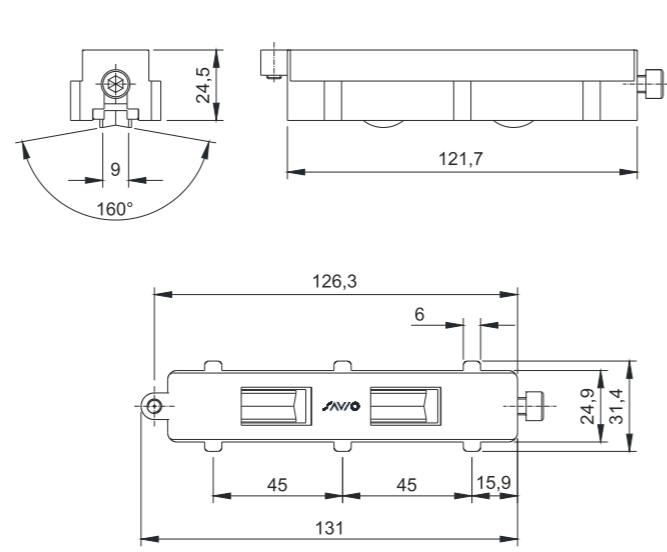

Rollers and kit for sliding systems

2156.4

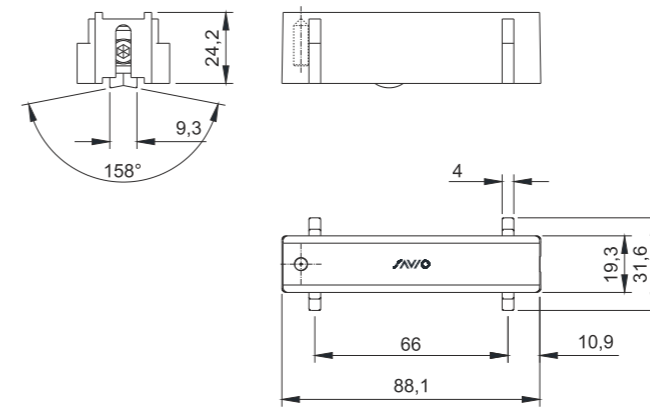

2157.4

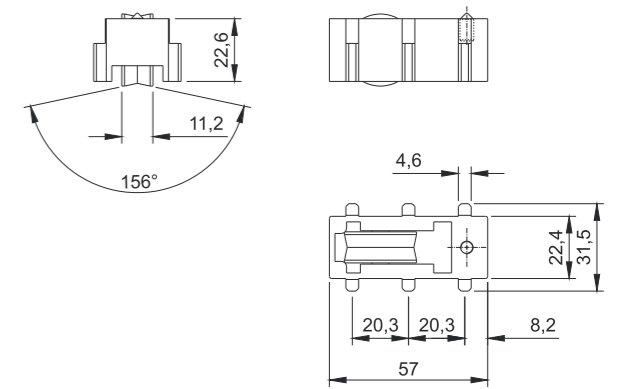

A29624300

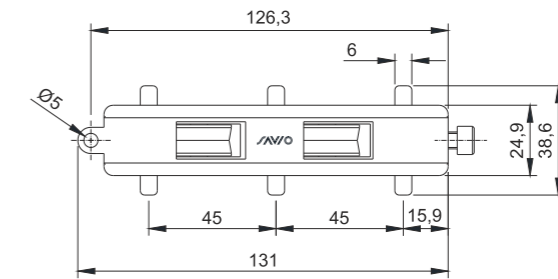
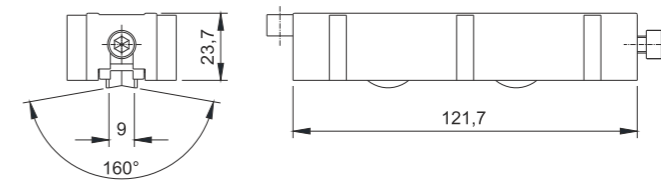

2152.1

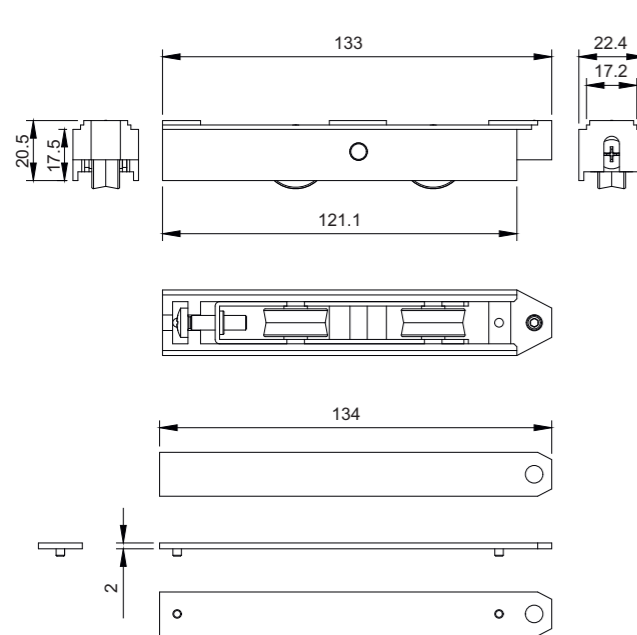

2156.1

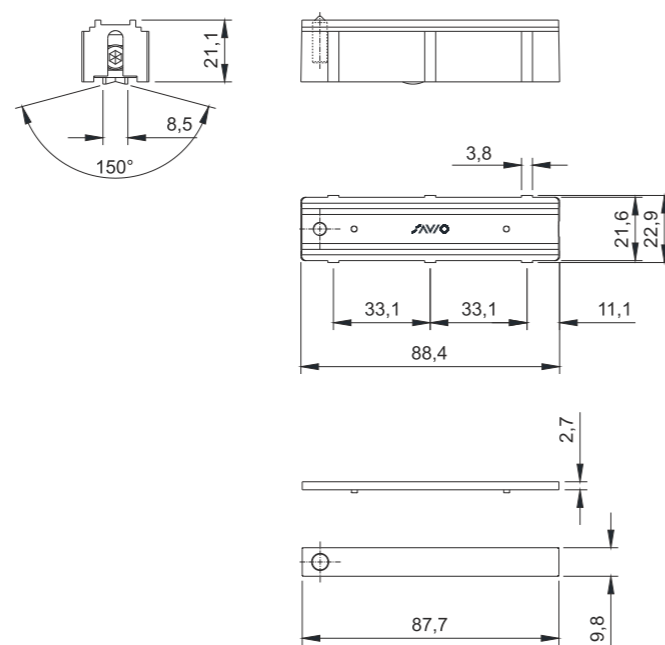

2203.1

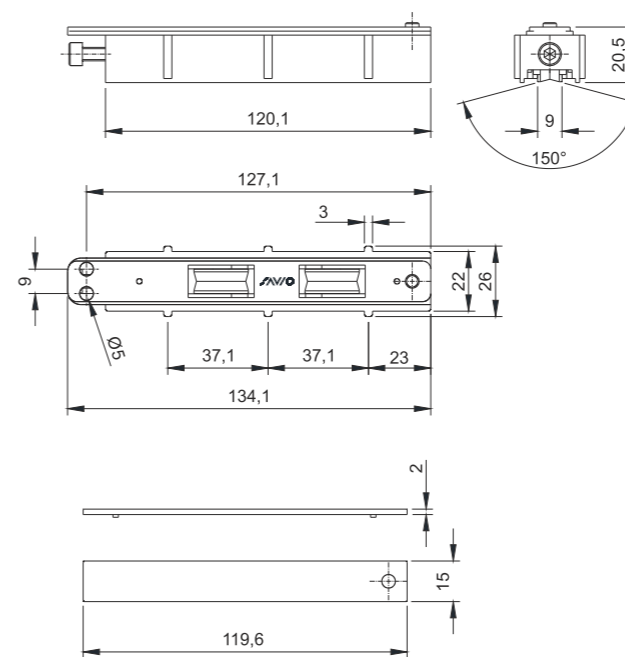

2203.2

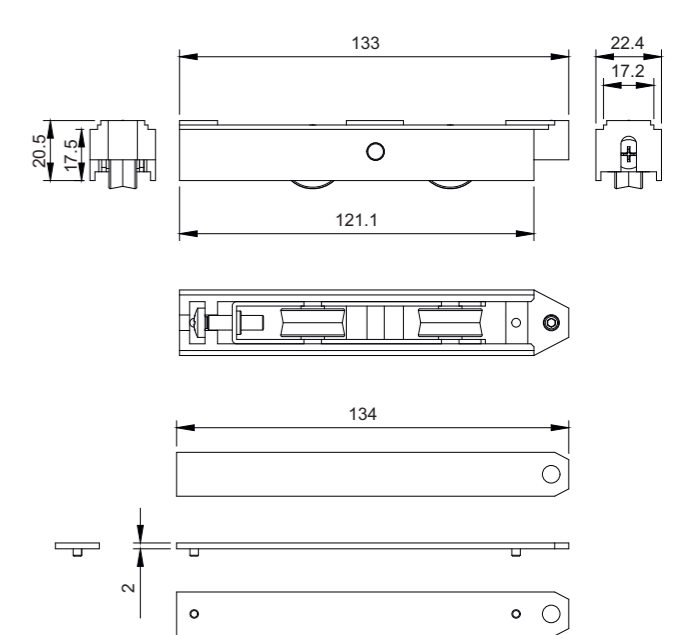

Suitability table of galvanized multi-point closures (7.5 mm backset)

Extruder	Profile	Kit x art.	Kit x art.	Kit x art.	Kit x art.	W mm
		2154.7/30	2154.7/60	2154.7/100	2154.7/180	
ALL.CO	Export 60 S	2154.811/30	2154.811/60	2154.811/100	2154.811/180	31
	Export 65 S	2154.804/30	2154.804/60	2154.804/100	2154.804/180	32
	Export 65 ST	2154.804/30	2154.804/60	2154.804/100	2154.804/180	31.5
	KS 50	2154.801/30	2154.801/60	2154.801/100	2154.801/180	30
	TRIAL.CO 65 S/TT - 90 S/TT	2154.804/30	2154.804/60	2154.804/100	2154.804/180	32
	WOOD S	2154.804/30	2154.804/60	2154.804/100	2154.804/180	32
	ETA	900 S/S TT	2154.804/30	2154.804/60	2154.804/100	2154.804/180
ETNALL	Serie 40000	2154.801/30	2154.801/60	2154.801/100	2154.801/180	32.5
	Serie 40600	2154.804/30	2154.804/60	2154.804/100	2154.804/180	32
	TT SC 80	2154.804/30	2154.804/60	2154.804/100	2154.804/180	32
HYDRO	Domal 40 S	2154.801/30	2154.801/60	2154.801/100	2154.801/180	32
	DOMAL SLIDE 80/PA 80	2154.803/30	2154.803/60	2154.803/100	2154.803/180	31
INDINVEST	GOLD 650 S	2154.804/30	2154.804/60	2154.804/100	2154.804/180	32
	GOLD 650 ST	2154.804/30	2154.804/60	2154.804/100	2154.804/180	32
METRA	NC 60 INT	2154.801/30	2154.801/60	2154.801/100	2154.801/180	32
SAPA	Win90 S	2154.802/30	2154.802/60	2154.802/100	2154.802/180	31.5
TO.MA.	ATLANTIS 78 S/STT	2154.803/30	2154.803/60	2154.803/100	2154.803/180	31.5
TP PROFILATI	EKOS 60 S	2154.804/30	2154.804/60	2154.804/100	2154.804/180	32
PROFILATI	PE 60 S	2154.801/30	2154.801/60	2154.801/100	2154.801/180	30
PASSERINI	Skeit 60	2154.811/30	2154.811/60	2154.811/100	2154.811/180	31.5
	Skeit 60 Super (anta 32 mm)	2154.811/30	2154.811/60	2154.811/100	2154.811/180	31.5
	Skeit 60 Super (anta 36 mm)	2154.804/30	2154.804/60	2154.804/100	2154.804/180	31
	Skeit 60 Super TT	2154.804/30	2154.804/60	2154.804/100	2154.804/180	31

Suitability table of galvanized multi-point closures (15 mm backset)

Extruder	Profile	Kit x art.	Kit x art.	Kit x art.	Kit x art.	Kit x art.	W mm
		2154.15/30	2154.15/60	2154.15/100	2154.15/180	2154.751/180	
ALL.CO	Export 60 S	2154.811/30	2154.811/60	2154.811/100	2154.811/180	/	38.5
	Export 65 S	2154.804/30	2154.804/60	2154.804/100	2154.804/180	/	39.5
	Export 65 ST	2154.804/30	2154.804/60	2154.804/100	2154.804/180	2154.804/180	39
	KS 50	2154.801/30	2154.801/60	2154.801/100	2154.801/180	/	37.5
	TRIAL.CO 65 S/90 S	2154.804/30	2154.804/60	2154.804/100	2154.804/180	/	39.5
	TRIAL.CO 65 TT/90 TT	2154.804/30	2154.804/60	2154.804/100	2154.804/180	2154.804/180	39.5
	WOOD S	2154.804/30	2154.804/60	2154.804/100	2154.804/180	2154.804/180	39.5
ETA	900 S/S TT	2154.804/30	2154.804/60	2154.804/100	2154.804/180	2154.804/180	39.5
ETNALL	Serie 40000	2154.801/30	2154.801/60	2154.801/100	2154.801/180	/	40
	Serie 40600	2154.804/30	2154.804/60	2154.804/100	2154.804/180	/	39.5
	TT SC 80	2154.804/30	2154.804/60	2154.804/100	2154.804/180	2154.804/180	39.5
HYDRO	Domal 40 S	2154.801/30	2154.801/60	2154.801/100	2154.801/180	/	39.5
	DOMAL SLIDE 80	2154.803/30	2154.803/60	2154.803/100	2154.803/180	/	38.5
	DOMAL SLIDE PA 80	2154.803/30	2154.803/60	2154.803/100	2154.803/180	2154.803/180	38.5
INDINVEST	GOLD 650 S	2154.804/30	2154.804/60	2154.804/100	2154.804/180	2154.804/180	39.5
	GOLD 650 ST	2154.804/30	2154.804/60	2154.804/100	2154.804/180	2154.804/180	39.5
METRA	NC 60 INT	2154.801/30	2154.801/60	2154.801/100	2154.801/180	/	39.5
SAPA	Win90 S	2154.802/30	2154.802/60	2154.802/100	2154.802/180	2154.802/180	39
TO.MA.	ATLANTIS 78 S/STT	2154.803/30	2154.803/60	2154.803/100	2154.803/180	/	39
TP PROFILATI	EKOS 60 S	2154.804/30	2154.804/60	2154.804/100	2154.804/180	2154.804/180	39.5
PROFILATI	PE 60 S	2154.801/30	2154.801/60	2154.801/100	2154.801/180	/	37.5
PASSERINI	Skeit 60	/	/	/	/	/	/
	Skeit 60 Super (anta 32 mm)	/	/	/	/	/	/
	Skeit 60 Super (anta 36 mm)	2154.804/30	2154.804/60	2154.804/100	2154.804/180	/	38.5
	Skeit 60 Super TT	2154.804/30	2154.804/60	2154.804/100	2154.804/180	2154.804/180	38.5

Suitability table of stainless steel multi-point closures (7.5 mm backset)

Extruder	Profile	Kit x art.	Kit x art.	Kit x art.	Kit x art.	W mm
		2154.7/30X	2154.7/60X	2154.7/100X	2154.7/180X	
ALL.CO	Export 60 S	2154.811/30	2154.811/60	2154.811/100	2154.811/180	30
	Export 65 S	2154.804/30	2154.804/60	2154.804/100	2154.804/180	31
	Export 65 ST	2154.804/30	2154.804/60	2154.804/100	2154.804/180	30.5
	KS 50	2154.801/30	2154.801/60	2154.801/100	2154.801/180	29
	TRIAL.CO 65 S/TT - 90 S/TT	2154.804/30	2154.804/60	2154.804/100	2154.804/180	31
	WOOD S	2154.804/30	2154.804/60	2154.804/100	2154.804/180	31
	ETA	900 S/S TT	2154.804/30	2154.804/60	2154.804/100	2154.804/180
ETNALL	Serie 40000	2154.801/30	2154.801/60	2154.801/100	2154.801/180	31.5
	Serie 40600	2154.804/30	2154.804/60	2154.804/100	2154.804/180	31
	TT SC 80	2154.804/30	2154.804/60	2154.804/100	2154.804/180	31
HYDRO	Domal 40 S	2154.801/30	2154.801/60	2154.801/100	2154.801/180	31
	DOMAL SLIDE 80/PA 80	2154.803/30	2154.803/60	2154.803/100	2154.803/180	30
INDINVEST	GOLD 650 S	2154.804/30	2154.804/60	2154.804/100	2154.804/180	31
	GOLD 650 ST	2154.804/30	2154.804/60	2154.804/100	2154.804/180	31
METRA	NC 60 INT	2154.801/30	2154.801/60	2154.801/100	2154.801/180	31
SAPA	Win90 S	2154.802/30	2154.802/60	2154.802/100	2154.802/180	30.5
TO.MA.	ATLANTIS 78 S/STT	2154.803/30	2154.803/60	2154.803/100	2154.803/180	30.5
TP PROFILATI	EKOS 60 S	2154.804/30	2154.804/60	2154.804/100	2154.804/180	31
PROFILATI	PE 60 S	2154.801/30	2154.801/60	2154.801/100	2154.801/180	29
PASSERINI	Skeit 60	2154.811/30	2154.811/60	2154.811/100	2154.811/180	30.5
	Skeit 60 Super (anta 32 mm)	2154.811/30	2154.811/60	2154.811/100	2154.811/180	30.5
	Skeit 60 Super (anta 36 mm)	2154.804/30	2154.804/60	2154.804/100	2154.804/180	30
	Skeit 60 Super TT	2154.804/30	2154.804/60	2154.804/100	2154.804/180	30

Suitability table of stainless steel multi-point closures (15 mm backset)

Extruder	Profile	Kit x art.	Kit x art.	Kit x art.	Kit x art.	W mm
		2154.15/30X	2154.15/60X	2154.15/100X	2154.15/180X	
ALL.CO	Export 60 S	2154.811/30	2154.811/60	2154.811/100	2154.811/180	38
	Export 65 S	2154.804/30	2154.804/60	2154.804/100	2154.804/180	39
	Export 65 ST	2154.804/30	2154.804/60	2154.804/100	2154.804/180	38.5
	KS 50	2154.801/30	2154.801/60	2154.801/100	2154.801/180	37
	TRIAL.CO 65 S/90 S	2154.804/30	2154.804/60	2154.804/100	2154.804/180	39
	TRIAL.CO 65 TT/90 TT	2154.804/30	2154.804/60	2154.804/100	2154.804/180	39
	WOOD S	2154.804/30	2154.804/60	2154.804/100	2154.804/180	39
ETA	900 S/S TT	2154.804/30	2154.804/60	2154.804/100	2154.804/180	39
ETNALL	Serie 40000	2154.801/30	2154.801/60	2154.801/100	2154.801/180	39.5
	Serie 40600	2154.804/30	2154.804/60	2154.804/100	2154.804/180	39
	TT SC 80	2154.804/30	2154.804/60	2154.804/100	2154.804/180	39
HYDRO	Domal 40 S	2154.801/30	2154.801/60	2154.801/100	2154.801/180	39
	DOMAL SLIDE 80	2154.803/30	2154.803/60	2154.803/100	2154.803/180	38
	DOMAL SLIDE PA 80	2154.803/30	2154.803/60	2154.803/100	2154.803/180	38
INDINVEST	GOLD 650 S	2154.804/30	2154.804/60	2154.804/100	2154.804/180	39
	GOLD 650 ST	2154.804/30	2154.804/60	2154.804/100	2154.804/180	39
METRA	NC 60 INT	2154.801/30	2154.801/60	2154.801/100	2154.801/180	39
SAPA	Win90 S	2154.802/30	2154.802/60	2154.802/100	2154.802/180	38.5
TO.MA.	ATLANTIS 78 S/STT	2154.803/30	2154.803/60	2154.803/100	2154.803/180	38.5
TP PROFILATI	EKOS 60 S	2154.804/30	2154.804/60	2154.804/100	2154.804/180	39
PROFILATI	PE 60 S	2154.801/30	2154.801/60	2154.801/100	2154.801/180	37
PASSERINI	Skeit 60	/	/	/	/	/
	Skeit 60 Super (anta 32 mm)	/	/	/	/	/
	Skeit 60 Super (anta 36 mm)	2154.804/30	2154.804/60	2154.804/100	2154.804/180	38
	Skeit 60 Super TT	2154.804/30	2154.804/60	2154.804/100	2154.804/180	38

Roller range suitability table

Extruder	Profile	2150.1	2151.1	2156.1	2152.1	2150.4	2151.4	2156.4	2157.4	A29624300
ALSISTEM	GLOBAL 60	•	•	•						
ALL.CO	EXPORT 60 S	•	•	•						
ALL.CO	EXPORT 65 S					•	•	•		
ALL.CO	EXPORT 65 ST					•	•	•		
ALL.CO	KS 50	•	•	•						
ALL.CO	KS 50 T	•	•	•						
ALL.CO	TRIAL.CO 65 S					•	•	•		
ALL.CO	TRIAL.CO 65 TT					•	•	•		
ALL.CO	TRIAL.CO 90 S					•	•	•		
ALL.CO	TRIAL.CO 90 TT					•	•	•		
ETA	900 S					•	•	•		
ETA	900 S TT					•	•	•		
ETA	START 410 SCORREVOLE	•	•	•						
ETNALL	SERIE 40000	•	•	•						
ETNALL	SERIE 40600					•	•	•		
ETNALL	TSC 80					•	•	•		
HYDRO BUILDING SYSTEMS	DOMAL 40 S	•	•	•						
INDINVEST	GOLD 650 S					•	•	•		
INDINVEST	GOLD 650 ST					•	•	•		
METRA	NC 60 INT	•	•	•						
MORELLI	MA 8700	•	•	•						
PONZIO	SLIDING 600	•	•	•						
PROFILATI	PE 60 S	•	•	•						
SAPA	WIN 90									•
TP PROFILATI	EKOS 60 S					•	•			
TP PROFILATI	EKOS 60 STH					•	•			
TRAF. PASSERINI ALLUMINIO	SKEIT 60	•		•						
TRAF. PASSERINI ALLUMINIO	SKEIT 60 SUPER	•	•	•						
TRAF. PASSERINI ALLUMINIO	SKEIT 60 SUPER TT	•	•	•						



Savio S.p.A.
Via Torino, 25 (S.S. 25) - 10050 Chiusa S. Michele (TO)
Tel. +39 011 964 34 64 - Fax +39 011 964 34 74
www.savio.it - export@savio.it

